

## FEATURES:

- ✿ 16.5" height from floor to the top of the bowl rim
- ✿ Low water consumption 1.00GPF
- ✿ Jet Siphonic gravity flushing system with 3" Flapper and Anti-Siphonic quiet fill valve.
- ✿ 2" full-glazed trap
- ✿ White or chrome plated trip lever
- ✿ 100% flushing test approved
- ✿ **Map test: 1,000g**
- ✿ Rough in: 305mm ( 12 inches)
- ✿ Installed Tank/Bowl/Seat Cover/Wax Ring Kit/2-box package
- ✿ Material: Vitreous China
- ✿ Warranty: (manufacturing faults only)  
10 years for VC / 1 year for parts
- ✿ Color: white
- ✿ Water Absorption: E≤0.5%

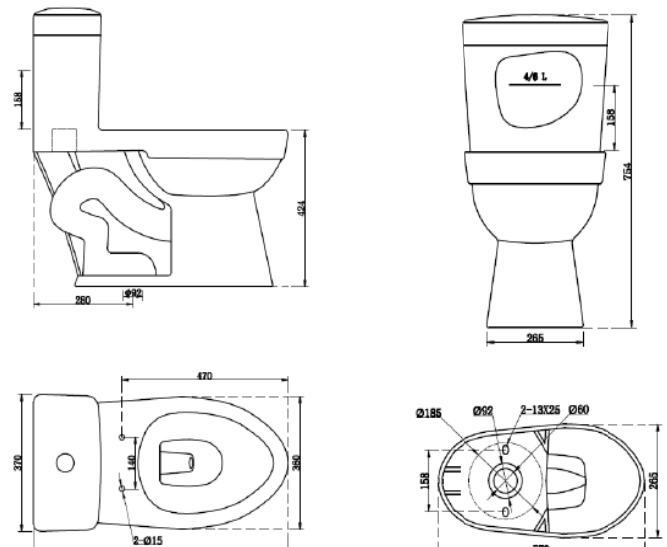

## Code/Standard Applied:



Meets or exceeds ASME A112.19.2-2003 / IAPMO/ANSI UPC 1-2003

Meets or exceeds CSA B45.0-02, B45.1-02 and B45S1-04



## Performance:



The Dolphin toilet scored the highest possible rating in independent laboratory performance tests with powerful and quiet flushing design.

**Warranty:** V/C – Limited 10 years / Parts – Limited 1 year

**NOTES:** These measurements are subject to change or cancellation. No responsibility is assumed for use of voided pages.

Dolphin products are covered by warranty for materials and workmanship only. Dolphin shall not be liable for any loss, damage, expense or inconvenience of any kind incurred, sustained, or suffered by any purchaser as a result of any defect or default in the Dolphin product. Especially from:

- a. The faulty installation of this Dolphin product;
- b. The combination, integration, or operation of this Dolphin product with product not manufactured by Dolphin for the purpose of forming a toilet suite;
- c. Where goods are used or adapted for a purpose for which they are not designed.